



## ETB Command Talk-Back System



### Features

- 10 lines selection
- Bridge Wing communication facility
- All Call / Group Call facility
- Extension buttons with memory light and buzzer indication of incoming calls.
- Signal oscillator
- Step volume control
- Dimable panel background light

The ETB Loudhailing Talk-Back system is a low cost 5 or 10 lines system, consisting of a combined central and operator unit and a comprehensive range of substations.

The physical dimensions of the units are based on the Euro DIN standard and fit neatly into integrated bridge solutions.

## Config. example

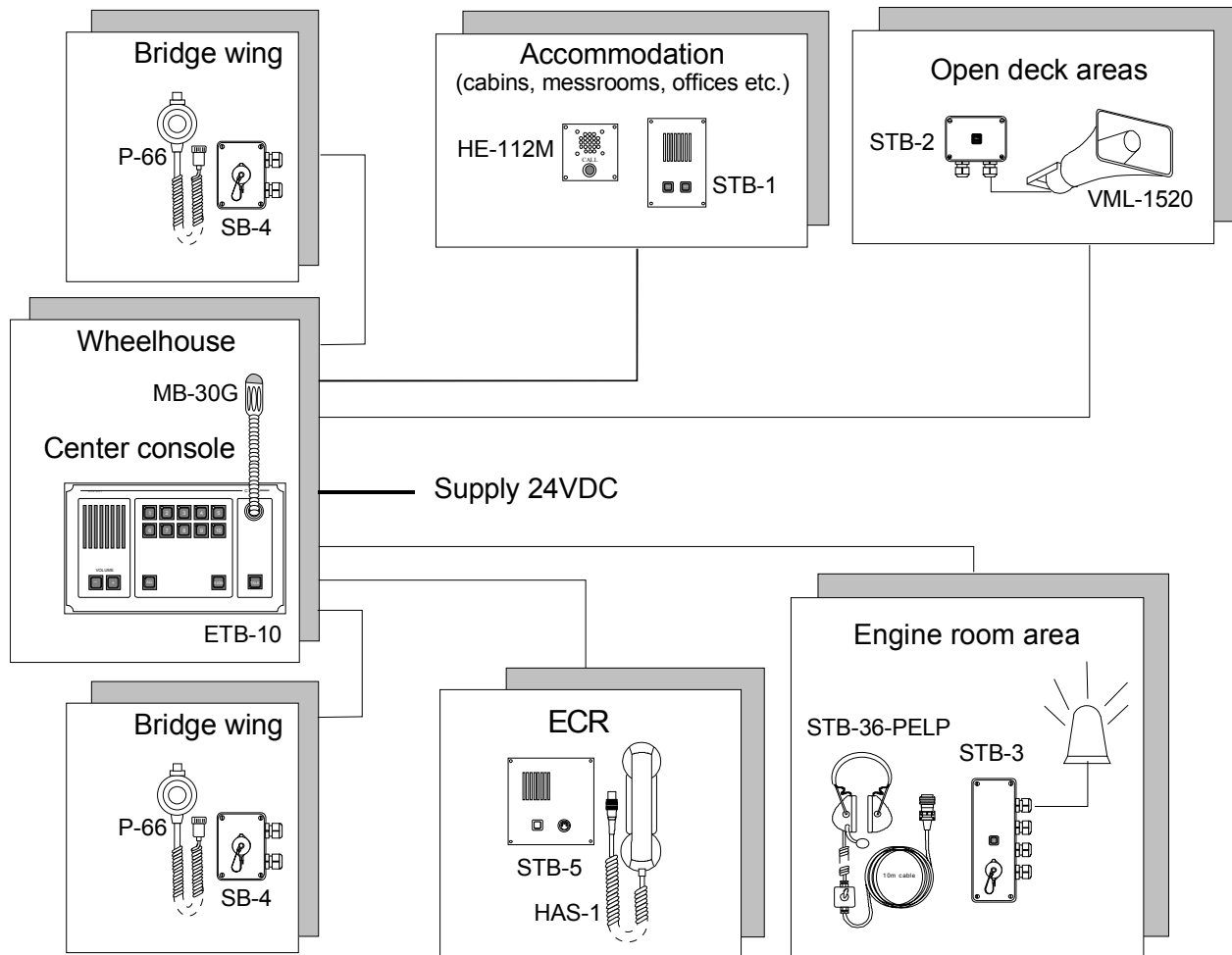

The ETB-5 and -10 operator panels have foil protective push button types with individual line buttons plus «ALL»-button.

The «TALK»-button controls the Talk-Listen function while the «CALL»-button activates external signal unit / relay box

Standard version has re-entrant speaker microphone with step volume control of the listening level. Handheld- or gooseneck microphones are available as options.

The substation connection cables are terminated in the ETB operator panel

For more detailed product descriptions:  
[www.zenitel.biz](http://www.zenitel.biz) \ Communication & Security Systems \ Zenitel Marine

